

Project Context

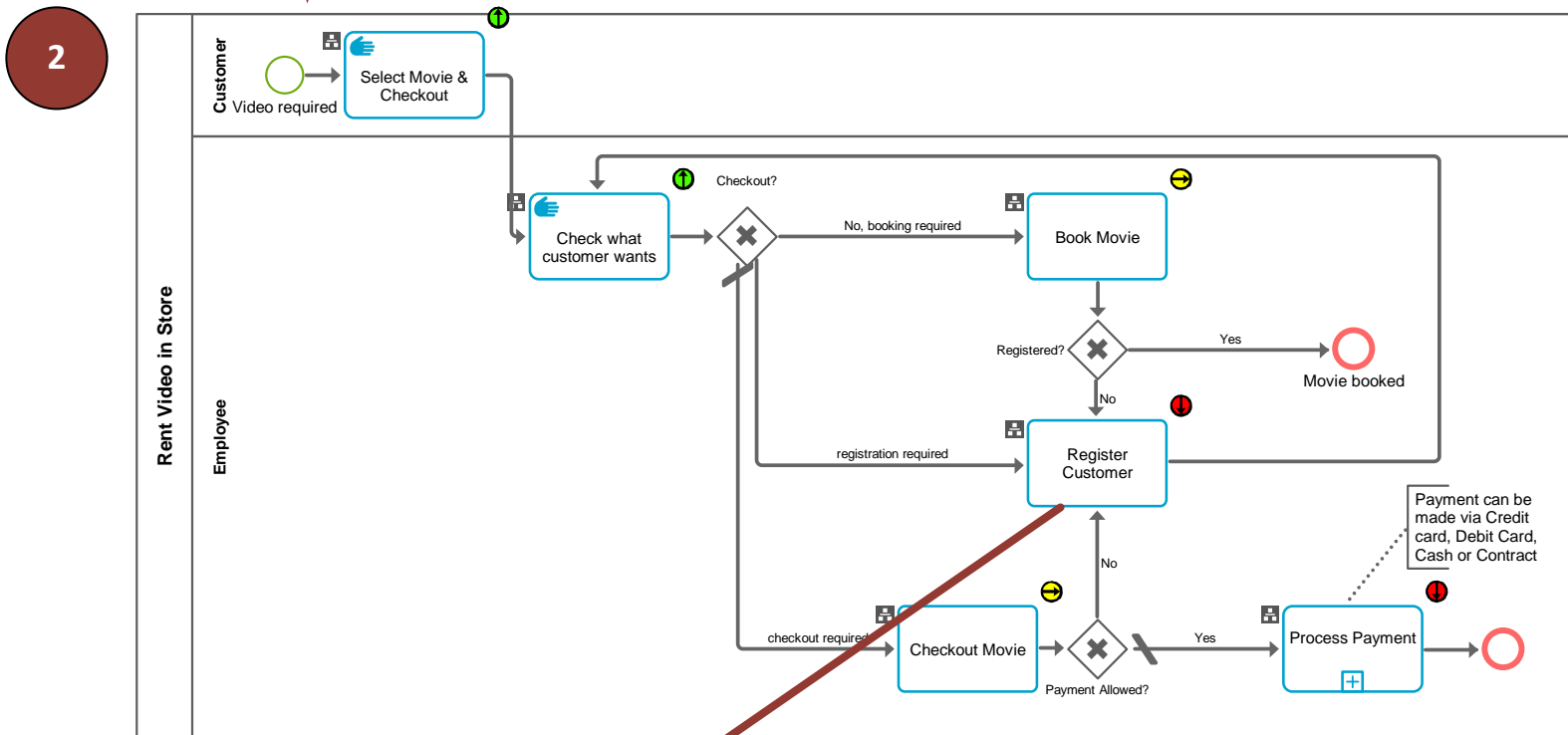

Top Level Process Design

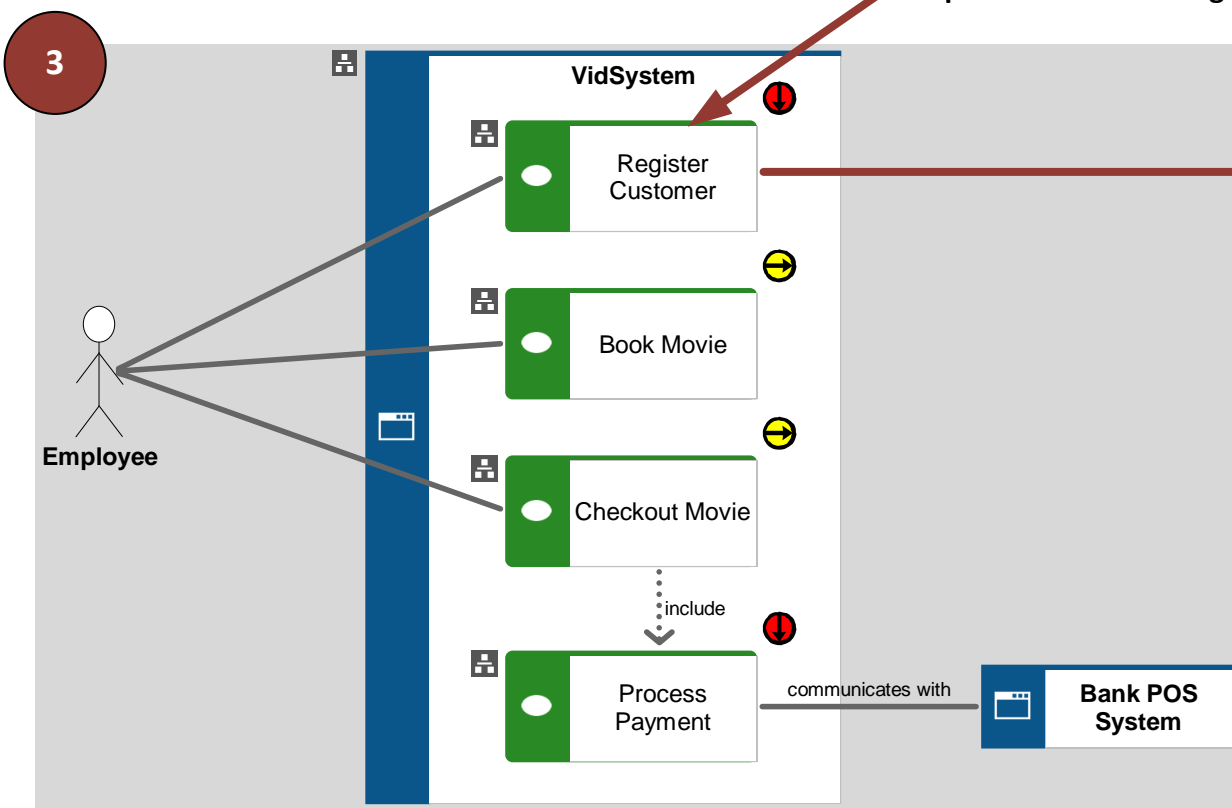

Sea Level Use Cases

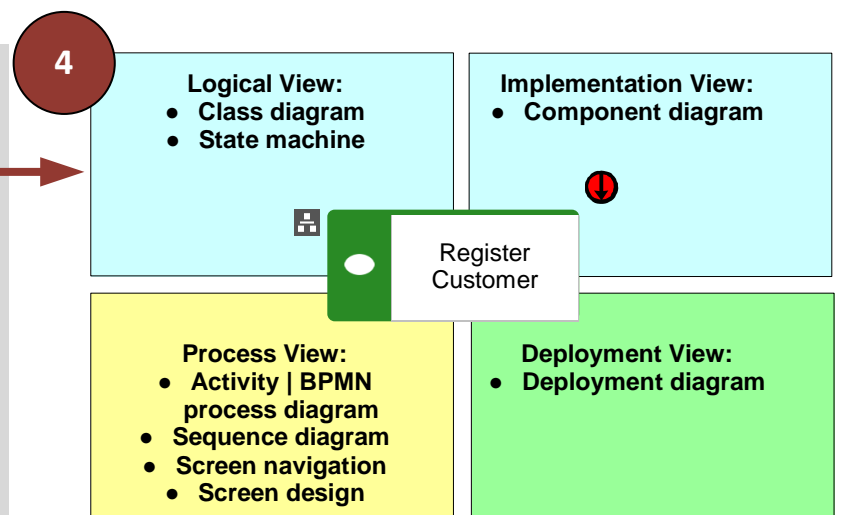

Detail Analysis & Design